

ELKHART  BRASS

BETTER PROTECTED



INDUSTRIAL FIRE FIGHTING EQUIPMENT

MONITORS / MASTER STREAM NOZZLES / INDUSTRIAL SYSTEMS / HANDLINE NOZZLES

SAFE  FLEET

Driving Safety Forward™

A WARM WELCOME



BETTER EQUIPPED TO FIGHT

Understanding the needs of the industrial market and offering quality products and solutions set Elkhart Brass apart. We are the oldest and most experienced manufacturer of innovative firefighting and fire protection equipment. Manufacturing over 2,000 products, used in virtually every aspect of fire fighting, makes Elkhart Brass a leader. Our products are found in fire departments around the world, building systems and offshore drilling sites, as well as in military, marine, mining and other industrial firefighting applications.

INDUSTRIAL MONITORS

| | |
|-----------------|----|
| Copperhead® | 07 |
| Stingray® | 09 |
| Spit-Fire® | 10 |
| Sidewinder® | 11 |
| Hydrant Mount | 12 |
| Manual Elevated | 13 |
| Portable Carts | 14 |

WATER POWERED OSCILLATORS

| | |
|-----------|----|
| WPO-2000™ | 15 |
|-----------|----|

MASTER STREAM NOZZLES

| | |
|---------------------------|----|
| X-Stream® | 19 |
| Select-O-Stream® | 22 |
| Select-O-Flow® | 24 |
| Mystery® | 25 |
| Hydro-Foam® Self-Educting | 27 |
| Foam Expansion Tubes | 30 |
| Smooth Bore Tips | 31 |
| Stream Shapers | 32 |

INDUSTRIAL SYSTEMS

| | |
|-------------|----|
| ERCM | 35 |
| ATEX | 39 |
| HRCM | 43 |
| HydroBlast™ | 47 |

HANDLINE NOZZLES

| | |
|-----------------------------|----|
| Industrial & Electrical Fog | 51 |
| Marine | 53 |

MORE INFORMATION

55

WHO WE ARE

WE'VE BEEN AROUND

Well known for its commitment to quality, value and customer service, Elkhart Brass celebrated its 100th anniversary in 2002. In 2015, Elkhart Brass was acquired by Safe Fleet creating the leading global provider of safety solutions for fleet vehicles. The combination of Elkhart Brass with FRC, FoamPro, and ROM enables the company to develop integrated systems of monitors, valves, foam proportioning, and electronic controls for the global emergency market. Elkhart Brass still operates at its original site in Elkhart, Indiana, utilizing the in-house foundry where aluminum and brass are poured daily. In addition to manufacturing, Elkhart Brass also specializes in product research and development, engineering, and product testing thanks to 3D rapid prototyping capabilities, a dedicated flow test facility, and a complete product machine shop.

CERTIFICATIONS AND QUALITY

Elkhart Brass is committed to quality, as demonstrated by its ISO-9001 Registered Quality System. Striving for ways to streamline processes while maintaining the quality craftsmanship customers expect, the company has excelled. An on-site foundry assures accurate documentation and quality of materials. On-site testing facilities are also a benefit. Because fire fighting is a dangerous occupation, the company makes a serious commitment to you by doing everything in its power to assure that when you use Elkhart Brass products, you have the highest quality and safest equipment available in the industry. As part of that commitment to quality, it continually strives to evaluate and innovate products, including upgrading certification credentials. Contact Elkhart Brass for further details or questions about a specific certification.

WARRANTY

Products are warranted in accordance with and subject to terms and conditions of Seller's standard Warranty Statement in effect on the date the applicable order is submitted. See Warranty Statement on website at www.safefleet.net/documents/ and download Elkhart Brass warranty document or use mobile phone to view here:



Industrial Fire Protection REDEFINED

LEARN ABOUT INDUSTRIAL FIRE CONTROL AND FIRE SUPPRESSION

Our helpful video content will be sure to leave you better informed about our products and how they can provide a solution for your unique needs. See detailed animations of devices and fire prevention/firefighting solutions for your industrial application including mining washdown, waste-to-energy, and more in aggressive atmospheres or even corrosive environments.



MOBILE APP



EVERYTHING NEEDED FOR FLOW TESTING NOW AT YOUR FINGERTIPS

- Smooth Bore Discharges & Flow/Pressure
- Nozzle Reaction for Smooth Bore Nozzles
- Nozzle Reaction for Fog Nozzles
- Pump Discharge Pressure for standard layouts, with ability to input hose coefficient depending on make and inside diameter
- Pump Discharge Pressure with elevation changes and appliances
- Pump Discharge Pressure for high-rise layouts
- Fire flow formula calculators for both the NFA and Iowa Formulas
- Also included in the app are direct links to the Brass Tacks Hard Facts® video series

AVAILABLE FOR FREE DOWNLOAD



INDUSTRIAL MONITORS

The Elkhart Brass Industrial monitor portfolio offers a wide range of solutions for industrial fire suppression application as well as mining and washdown applications. Elkhart Brass Industrial monitors are designed for use in several vertical markets including Oil and Gas, Mining and Construction, Waste-to-Energy and Washdown markets. Most Elkhart Brass Industrial Monitors are FM Approved and CE Certified.



MANUAL FIXED

Built to give you years of trouble-free service, our range of manual fixed monitors is sure to have you covered for all of your fixed fire protection needs.

- Tiller bar or handwheel control options
 - Built of brass construction for years of reliable service in the harshest environments
 - Wide variety of flow rates
- | | |
|---------------|---------------|
| ▪ COPPERHEAD® | ▪ SPIT-FIRE® |
| ▪ STINGRAY® | ▪ SIDEWINDER® |



MANUAL FIXED WITH BUILT-IN VALVE

These monitors add a built-in valve to some of our most popular manual fixed monitors for quick acting waterflow applications and simplifying site installation.

- Built-in ball valve for fast acting operation
 - Tiller bar or handwheel control options
 - Built of brass construction for years of reliable service in the harshest environments
- | | |
|-----------------|---------------|
| ▪ COPPERHEAD IV | ▪ STINGRAY IV |
|-----------------|---------------|



HYDRANT MOUNTED

Utilizing a fire hydrant as their water source, easy-to-install hydrant mounted monitors offer an effective solution to fixed fire protection.

- Mounts directly to hydrant outlet
 - Single handwheel control
 - Built of brass construction for years of reliable service in the harshest environments
- | |
|------------|
| ▪ STINGRAY |
|------------|

MANUAL ELEVATED

Manual elevated monitors offer a solution when elevated fire streams are necessary for adequate fire protection. Available in a variety of heights, they are necessary for adequate fire protection rising to any challenge.

- Allows for an elevated stream for specific applications
 - Various height options
 - Brass and stainless steel construction for years of reliable service in the harshest environments
- | | |
|-------------|----------|
| ▪ SPIT-FIRE | ▪ PYTHON |
|-------------|----------|



COPPERHEAD®

MODELS:

8593-02 (TILLER BAR CONTROL)

8593-03 (DUAL HANDWHEEL CONTROL)

8593-IV (TILLER BAR CONTROL WITH BUILT-IN VALVE)

Copperhead® manual monitors are rugged maintenance-free monitors designed for corrosive and non-corrosive environment applications. Each configuration of the Copperhead monitor has extremely low friction loss and, in conjunction with advanced Elkhart Brass nozzle technology, ensures optimal flow efficiency and stream reach.

Copperhead monitors are FM Approved to the current edition of FM 1421 standard.

KEY FEATURES:

- 1250 gpm (4750 LPM) maximum flow rate
- 200 psi (14 BAR) maximum operating pressure
- -45° to +90° (135°) vertical travel range
- 360° continuous horizontal travel range
- Full 3" unobstructed waterway with cast-in vanes to ensure superior stream quality
- Positive brass T-handle locks furnished for both vertical and horizontal movements
- Tiller bar and dual handwheel manual control options
- FM Approved for use with Elkhart Brass WPO-2000™ enables automation of the horizontal oscillation without the need of electric control unit
- Rugged brass construction for use in corrosive environments and seawater applications



8593-IV (TILLER BAR WITH BUILT-IN VALVE)



8593-03 HANDWHEEL

8593-02 TILLER BAR

Recommended Nozzles & Accessories



SM-1250B



IMS-500



WPO-2000™



HF-13



181 - DELUGE TIP



282-B - STREAM SHAPER



CJB



CSW-LB

STINGRAY®

MODEL:
8393
8393-IV WITH BUILT-IN BALL VALVE

The Elkhart Brass Stingray® manual monitor low profile design enables use in space constraint applications. The Stingray monitor is FM Approved to the current edition of the FM1421 standard and suitable for corrosive and non-corrosive environment applications.

KEY FEATURES:

- 1250 gpm (4750 LPM) maximum flow rate
- 200 psi (14 BAR) maximum operating pressure
- -60° to +90° (150°) vertical travel range
- 360° continuous horizontal travel range
- Full 3" unobstructed waterway
- Handwheel control for vertical discharge travel range
- Available with built-in ball valve, Model 8393-IV
- Rugged brass construction for use in corrosive environments and seawater applications



Recommended Nozzles & Accessories



8393-IV WITH BUILT-IN BALL VALVE

SPIT-FIRE®

MODEL: 8394-02 HANDWHEEL OPTION

The Elkhart Brass manual Spit-Fire® monitors are designed to provide up to 360° horizontal rotation with dual handwheel or tiller bar control mechanism options. The Spit-Fire manual monitor is FM Approved to the current edition of FM1421 standard and suitable for corrosive and non-corrosive environment applications.

KEY FEATURES:

- 2000 gpm (7550 LPM) maximum
- 200 psi (14 BAR) maximum operating pressure
- -45° to +90° (135°) vertical travel
- 360° continuous horizontal travel
- 4" waterway with cast-in vane to optimize stream reach and performance
- Easy to operate tiller bar or dual handwheel control options
- FM Approved for use with Elkhart Brass WPO-2000™ enables automation of the horizontal oscillation without the need of electric control unit
- Rugged brass construction for use in corrosive environments and seawater applications



8394-121 TILLER BAR



Recommended Nozzles & Accessories



SIDEWINDER®

MODEL: 8392

Designed for lower flow needs and compact applications in harsh environments, the Sidewinder® has a 2" fully-vented waterway for exceptional stream performance. It has an extremely low and compact profile ideal for anywhere space is at a premium. Fast action tiller bar control and horizontal and vertical locks allow the operator to put the stream where it needs to go.

KEY FEATURES:

- Rated for 500 gpm (1900 LPM)
- 200 psi (14 BAR) maximum operating pressure
- 1.5" male outlet
- 2" female NPT inlet
- Rugged brass construction for use in corrosive environments and seawater applications
- Red urethane finish

TRAVEL RANGE:

- Vertical -45° to +90° (135°)
- Horizontal continuous (360°)



Recommended Nozzles & Accessories



185-B
SMOOTH BORE



L-205-B



205-B

HYDRANT MOUNT

MODEL: 8393-H

The Elkhart Brass Hydrant mount manual monitor design enables installation of the monitor on fire hydrants. The hydrant mount monitors are FM Approved to the current edition of the FM1421 standard and suitable for corrosive and non-corrosive environment applications.

KEY FEATURES:

- Model 8393 H: 1250 gpm (4750 LPM) maximum flow rate
- 200 psi (14 BAR) maximum operating pressure
- -70° to +80° (160°) vertical travel range
- 360° continuous horizontal travel range
- Full 3" unobstructed waterway
- Handwheel control for vertical discharge travel range
- Rugged brass construction for use in corrosive environments and seawater applications

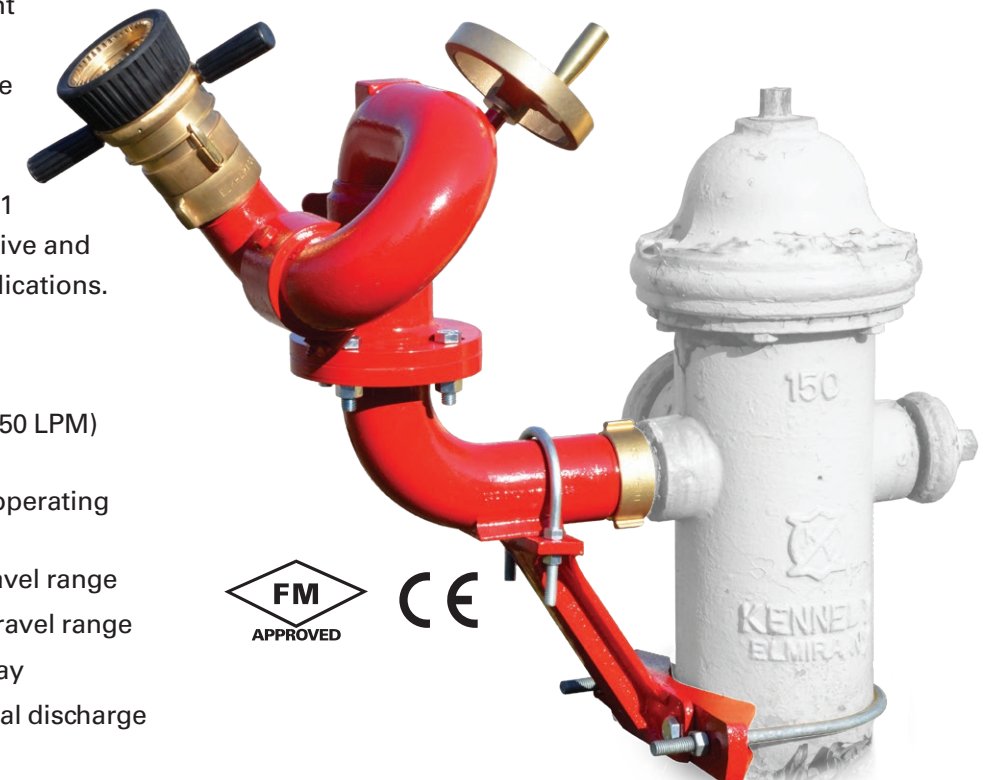

Recommended Nozzles & Accessories



HF-500
HYDRO-FOAM®



CJN-B



J



181
DELUGE TIP



282-B
STREAM SHAPER

MANUAL ELEVATED

Elkhart Brass manual elevated monitors are designed to enable control of fire streams from ground level when elevated streams are necessary for adequate fire protection. They are available in freestanding or supported models with customer supplied risers.



299-11EL Elevated Monitor

The Elkhart Brass 299-11EL Elevated monitor is a completely free standing and available in standard heights from 10 feet to 40 feet.

KEY FEATURES:

- Brass and stainless steel construction
- 750 gpm (2900 LPM) maximum flow rate
- 200 psi (14 BAR) optimal pressure
- -37° to +45° (78°) vertical travel range
- 360° Continuous horizontal travel range
- Tiller with locks control
- Available in standard heights from 10 feet to 40 feet
- Red urethane enamel finish



8394-02RC Elevated Monitor

The Elkhart Brass 8394-02RC Elevated Monitor offers an elevated monitor solution for installation on a customer supplied intermediate riser pipe. A Model 295 support bearing is to be used every 10 feet.

KEY FEATURES:

- Brass and stainless steel construction
- Up to 1000 gpm (3800 LPM) maximum flow rate
- 200 psi (14 BAR) maximum operating pressure
- -45° to +90° (135°) vertical travel range
- 360° Continuous horizontal travel range
- Dual handwheel control
- Red urethane enamel finish

Optional Products

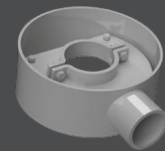

295 Support Bearing

- Designed so that 4" waterway and vertical control rod can rotate inside of bearing. 3" NPT female for attaching to adjacent support
- Red urethane enamel finish

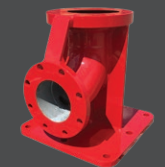

90° Intake Base

- Used with 299-11EL and 8394-02RC monitors
- Carbon steel construction
- 6"-150# and 6"-300# flange inlet
- 4"-150#, 6"-150#, and 6"-300# flange outlet
- Full 4" waterway
- Red epoxy finish

Recommended Products



CJ-B-RC
C/JN-B-RC



283-B
STREAM SHAPER



181
DELUGE TIP

PORTABLE CARTS

The Elkhart Brass portable wheel cart comes furnished with flow-efficient, built-in 4" manifold. Two and four wheel options are offered with pneumatic tires and wheel locks.

KEY FEATURES:

- Brass and stainless steel construction
- Up to 1000 gpm (3800 LPM) maximum flow rate
- 200 psi (14 BAR) maximum operating pressure
- +70° to +20° (50°) vertical travel range
- Single 4" or 5" storz and double 2.5" NHT inlet options



WPO-2000™

WATER POWERED MONITOR OSCILLATOR

The Elkhart Brass WPO-2000™ is the most versatile and reliable water powered monitor oscillator system available to the fire protection industry today.



The FM Approved, low profile WPO-2000™ is designed to provide up to 30°/sec oscillation speed when installed between a monitor and a valve or manifold/hydrant outlet. Dependability and ease of installation and operation are hallmarks of Elkhart Brass monitors. The WPO-2000, combined with an Elkhart Brass monitor, provides high quality, system reliability and the flexibility required by modern land-based and water-based industrial fire protection applications. This combination offers the industry the most cost effective and reliable fixed monitor solution in its class.



WPO-2000 KEY FEATURES:

- Modular oscillator design enables compatibility with the Elkhart Brass Copperhead® and Spit-Fire® monitors, along with other manufacturer models
- 316 stainless steel and 85 brass construction provides outstanding corrosion resistance for use in corrosive environments
- Easily accessible external controls enable speed and travel range adjustment while system is in operation
- Double reduction oil bath gearbox ensures reliability and extends the life for heavy use
- Manual override feature allows manual control at any time
- 15° to 120° arc of oscillation range provides wide coverage area
- 200 psi (14 BAR) maximum operating pressure
- Product flexibility allows support to most monitors with up to 2000 gpm (7570 LPM) flow rates
- Compact size enables ease of installation

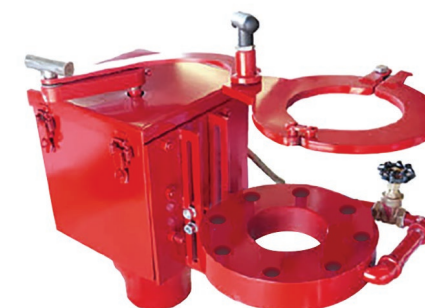

WPO-2000 APPLICATIONS:

- Oil Refineries
- Oil Rigs
- Petrochemical
- Processing Plants
- Tank Farms
- Fueling Areas
- Docks
- Heliports
- Railroad Yards
- Chemical
- Processing Plant
- Coal Storage
- Lumber Mills
- Paper Mills

A large industrial facility, possibly a power plant or refinery, is shown with a red vertical pipe on the right side. A powerful stream of water is being emitted from the top of the pipe, creating a large, white, misty plume that fills the upper right portion of the frame. The background shows a cloudy sky and some distant structures. The overall scene is industrial and powerful.

MASTER STREAM NOZZLES

Elkhart Brass industrial Master Stream nozzles provide a wide range of nozzle solutions that seamlessly integrate with the Elkhart Brass industrial monitor offerings. The Elkhart Brass Master Stream nozzle solutions include constant flow, automatic and Hydro-Foam® nozzles designed to optimize nozzle performance. Most Master Stream nozzles are either FM Approved or UL Listed.



X-STREAM[®] NOZZLES

Built to perform, the X-Stream[®] Series automatic nozzles are designed to self-adjust based on variable or reduced pressure and flow to maintain an effective stream with maximum reach. Manual models feature large handles for easy stream pattern adjustment. Electric versions include sealed connectors and motors along with a manual override. They have several global certifications and approvals including FM, ATEX, and IECEx. Special models are designed for use in hazardous locations and for gas mitigation applications.

KEY FEATURES:

- Flow rates: 350 - 2000 gpm (1330 - 7550 LPM)
- Calibrated to operate at lower inlet pressures of 70 - 80 psi (4.8 - 5.5 BAR)
- Adjustable patterns from straight stream to narrow fog (30°) and wide fog (90°)
- Precision cut metal teeth for exceptional fog pattern
- Brass construction for corrosive and non-corrosive environment applications with some models even having an electroless nickel-plated coating for extra protection
- Some models are made of hardcoated aluminum with hard anodized finish

SM-1250B

- Flow range of 350-1250 gpm @ 75 psi (1330-4750 LPM @ 5 BAR)
- Large handles for manual stream pattern adjustment
- 2.5" or 3.5" inlet
- FM Approved



SM-1250BE

- Flow range of 350-1250 gpm @ 75 psi (1330-4750 LPM @ 5 BAR)
- Stream pattern remotely controlled via robust electronic motor design
- 2.5" inlet or 3.5" inlet



SM-1250HB

- Flow range of 350-1250 gpm @ 75 psi (1330-4750 LPM @ 5 BAR)
- Stream pattern remotely controlled via robust hydraulic actuator
- 2.5" inlet or 3.5" inlet



SM-2000B

- Flow range of 500-2000 gpm @ 80 psi (1900-7550 LPM @ 5.5 BAR)
- Large handles for manual stream pattern adjustment
- 3.5" inlet
- FM Approved



SM-2000BE

- Flow range of 500-2000 gpm @ 80 psi (1900-7550 LPM @ 5.5 BAR)
- Stream pattern remotely controlled via robust electronic motor design
- 3.5" inlet



SM-2000HB

- Flow range of 500-2000 gpm @ 80 psi (1900-7550 LPM @ 5.5 BAR)
- Stream pattern remotely controlled via robust hydraulic actuator
- 3.5" inlet



X-STREAM[®]

AUTOMATIC MASTER STREAM

Approved for Hazardous Location Use

- FM Approved for Class I Div 2 hazardous location rated

OR

- ATEX certified for Zone 1, ATEX Zone 2, ATEX Zone 21, ATEX Zone 22
- IECEx certified Zone 1, IECEx Zone 2, IECEx Zone 21, IECEx Zone 22

SM-1250BE-HL

- Flow range of 350-1250 gpm @ 75 psi (1330-4750 LPM @ 5 BAR)
- Stream pattern remotely controlled via robust electronic motor design
- 3.5" inlet



SM-2000BE-HL

- Flow range of 500-2000 gpm @ 80 psi (1900-7550 LPM @ 5.5 BAR)
- Stream pattern remotely controlled via robust electronic motor design
- 3.5" inlet



Gas Mitigation Master Stream Nozzles:

Designed for with an wide 120° fog pattern for gas mitigation applications

SM-1250BE-HLGM

- Flow range of 350-1250 gpm @ 75 psi (1330-4750 LPM @ 5 BAR)
- Stream pattern remotely controlled via robust electronic motor design
- 3.5" inlet



SM-2000BE-HLGM

- Flow range of 500-2000 gpm @ 80 psi (1900-7550 LPM @ 5.5 BAR)
- Stream pattern remotely controlled via robust electronic motor design
- 3.5" inlet



SELECT-O-STREAM[®]

MASTER STREAM

The Elkhart Brass Select-O-Stream[®] nozzles are constant flow with a fully machined waterway that ensures excellent stream quality. The Select-O-Stream nozzles are FM Approved.

KEY FEATURES:

- Brass construction for corrosive and non-corrosive environment applications
- Pattern easily changed under flowing conditions from straight stream to 90° fog
- Grease zerk fitting for easy lubrication of tip threads
- Satin and cast brass finish
- No-twist shutoff

CJ-B

- Flow Rates: 350 gpm @ 100 psi (1330 LPM @ 7 BAR)
500 gpm @ 100 psi (1900 LPM @ 7 BAR)
- 2.5" inlet
- FM Approved

Aluminum version available: Model CJ



CJN-B

- Flow Rates: 750 gpm @ 100 psi (2900 LPM @ 7 BAR)
1000 gpm @ 100 psi (3800 LPM @ 7 BAR)
- 2.5" inlet
- FM Approved

Aluminum version available: Model CJN



CJ-B-RC

- Flow Rates: 350 gpm @ 100 psi (1330 LPM @ 7 BAR)
500 gpm @ 100 psi (1900 LPM @ 7 BAR)
- Stream adjustment via cables for use with manual elevated monitors
- 2.5" inlet
- FM Approved



CJN-B-RC

- Flow Rates: 750 gpm @ 100 psi (2900 LPM @ 7 BAR)
1000 gpm @ 100 psi (3800 LPM @ 7 BAR)
- Stream adjustment via cables for use with manual elevated monitors
- 2.5" inlet
- FM Approved

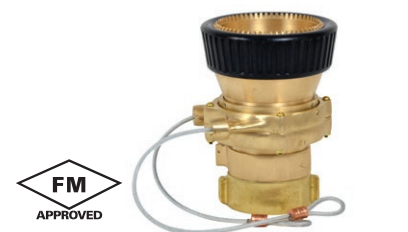

SELECT-O-STREAM[®]

MASTER STREAM (CONTINUED)



SELECT-O-FLOW[®]

MASTER STREAM

Elkhart Brass Select-O-Flow[®] Master Stream nozzles are selectable flow constant flow type nozzles. The Select-O-Flow nozzles design enables flow rate change while nozzle is operating under flow condition.



KEY FEATURES:

- Brass construction for corrosive and non-corrosive environment applications
- Pattern easily changed under flowing conditions from straight stream to 90° fog
- Satin and cast brass finish

IMS-350

- Flow Rate: 350 gpm @ 100 psi (1330 LPM @ 7 BAR)
- Wide 140° fog pattern
- 2.5" inlet

IMS-500

- Flow Rate: 500 gpm @ 100 psi (1900 LPM @ 7 BAR)
- Wide 140° fog pattern
- 2.5" inlet
- FM Approved

IMS-750

- Flow Rate: 750 gpm @ 100 psi (2900 LPM @ 7 BAR)
- 2.5" inlet
- FM Approved

IMS-1000

- Flow Rate: 1000 gpm @ 100 psi (3800 LPM @ 7 BAR)
- 2.5" inlet
- FM Approved



CSW-LB

- Flow Rate: 350/500/750/1000/1250 gpm @ 100 psi (1300/1900/2900/3800/4750 LPM @ 7 BAR)
- 2.5" inlet



Aluminum Versions Available:

CSW-L

- Flow Rate: 350/500/750/1000/1250 gpm @ 100 psi (1300/1900/2900/3800/4750 LPM @ 7 BAR)
- 2.5" inlet



CSW

- Flow Rate: 350/500/750 gpm @ 100 psi (1300/1900/2900 LPM @ 7 BAR)
- 2.5" inlet

MYSTERY[®] MASTER STREAM

The Elkhart Brass Mystery[®] nozzle design has a twist shut-off feature with models flowing up to 2000 gpm (7550 LPM) maximum flow rates.

KEY FEATURES:

- Brass construction for corrosive and non-corrosive environment applications
- Pattern easily changed under flowing conditions from straight stream to 90° fog
- Grease zerk fitting for easy lubrication of tip threads
- Satin and cast brass finish
- Twist shutoff included



FIXED SYSTEM NOZZLES MASTER STREAM

Designed for use in fixed system applications. Adjustable nozzles can be pre-set at the factory or set in the field at time of installation. The fog pattern, which can be set up to 120°, can also easily be set or adjusted on site.



J

- Flow Rates: 350 gpm @ 100 psi (1330 LPM @ 7 BAR)
500 gpm @ 100 psi (1900 LPM @ 7 BAR)
- 2.5" inlet



JN

- Flow Rate: 1000 gpm @ 100 psi
(3800 LPM @ 7 BAR)
- 2.5" inlet

CJK

- Flow Rates: 1250 gpm @ 100 psi (4750 LPM @ 7 BAR)
1500 gpm @ 100 psi (5700 LPM @ 7 BAR)
1750 gpm @ 100 psi (6650 LPM @ 7 BAR)
2000 gpm @ 100 psi (standard) (7550 LPM @ 7 BAR)
- 3.5" inlet



NTS-C

- Adjustable flow rate from 5-40 gpm (20-150 LPM)
- Adjustable fog pattern up to 120°
- 0.75" male NPT inlet standard, female optional
- Rugged brass construction and finish



NTL-C

- Adjustable flow rate from 40-100 gpm (150-380 LPM)
- Adjustable fog pattern up to 120°
- 1.0" male NPT inlet standard, female optional
- Rugged brass construction and finish



NT-C

- Adjustable flow rate from 100-250 gpm (380-950 LPM)
- Adjustable fog pattern up to 120°
- 1.5" male NPT inlet standard
- Rugged brass construction and finish



HYDRO-FOAM[®] SELF-EDUCTING MASTER STREAM

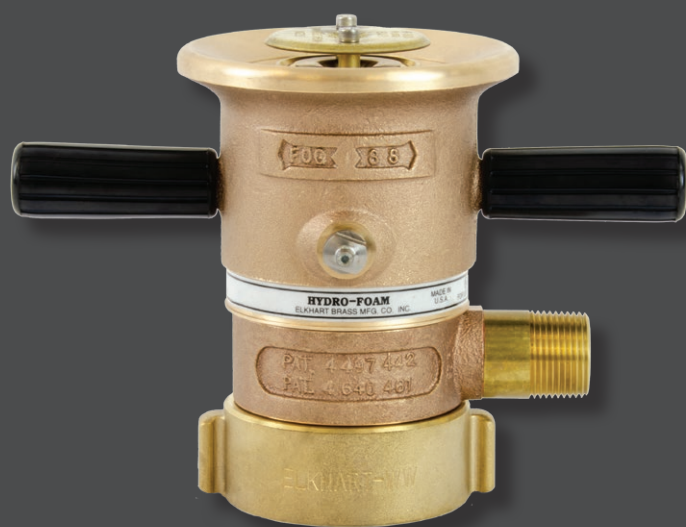

The Elkhart Brass Hydro-Foam[®] self-educating nozzle design enables these nozzles to flow foam solution without the need for special foam mixing equipment. The design of the Elkhart Brass Hydro-Foam nozzle provides the flexibility and reliability required for applying foam solution in modern industrial firefighting applications.

KEY FEATURES:

- Brass construction for corrosive and non-corrosive environment applications
- Pattern easily changed under flowing conditions from straight stream to 90° fog
- Built-in metering device accurately proportions foam at the selected rate
- Suitable for Class A and Class B foams including AFFF, AR-AFFF, and fluoroprotein foam concentrates

HF-350 / HF-500

- Rated for 350 gpm (1330 LPM) or 500 gpm @ 100 psi (1900 LPM @ 7 BAR)
- Clear vinyl 9' (2.7 m) pick up hose included
- Pick up rates: ½%, 1%, 3%, 6% (HF-350) ½%, 1%, 3% (HF-500)
- 2.5" female swivel inlet
- Satin brass or chrome plated finish (Aluminum version available)
- UL Listed



SELF-EDUCTING NOZZLE ACCESSORIES

HF-350 and HF-500 Quick Connect Coupling

- This brass quick-connect coupling provides an easy way of attaching/detaching pick-up hose
- Satin brass or chrome plated finish



Shut-Off Valve

- Quarter-turn ball valve for positive shut-off of foam supply
- Attaches to foam inlet of nozzle
- Satin brass or chrome plated finish



Metering Valve

- Quarter-turn ball valve for instant proportioning change
- Specify
 - 1% / 3% configuration
 - 3% / 6% configuration (HF-350 only)
- Satin brass or chrome plated finish

Drum Pick Up Kit #1

- Designed for use with HF-350 and HF-500
- Allows foam inlet of the nozzle to be pre-connected to a drum or tote of concentrate
- Includes PVC pick up tub with shut-off valve, brass vacuum breaker, and clear reinforced vinyl 8' (2.4 m) pick up hose



HF13-750 / HF13-1000

- Rated for 750 gpm (2900 LPM) or 1000 gpm @ 100 psi (3800 LPM @ 7 BAR)
- Clear vinyl 9' (2.7 m) pick up hose included
- Pick up rates: 1% and 3%
- 2.5" female swivel inlet
- Cast and satin brass finish
- Proportioning disc or metering valve options for regulating foam



Drum Pick Up Kit #2

- Designed for use with HF13-750 / HF13-1000
- Allows foam inlet of the nozzle to be pre-connected to a drum or tote of concentrate
- Includes PVC pick up tub with shut-off valve, brass vacuum breaker, and clear reinforced vinyl 8' (2.4 m) pick up hose



XTREME HYDRO-FOAM® NOZZLES**KEY FEATURES:**

- Automatic flow nozzle design maximizes reach based on available water supply across a range of flows
- Lightweight aluminum construction
- Pattern easily changed under flowing conditions from straight stream to 90° fog
- Hard coated aluminum finish

SM-1000-HF

- Rated for 350-1000 gpm @ 100 psi (1130-1900 LPM @ 7 BAR)
- Pick up rates: 1% and 3%
- Clear vinyl 9' (2.7 m) pick up hose included
- 2.5" female swivel inlet

**SM-2000-HF**

- Rated for 750-2000 gpm @ 100 psi (2900-7550 LPM @ 7 BAR)
- Pick up rate: 1%
- Clear vinyl 9' (2.7 m) pick up hose included
- 3.5" female swivel inlet

SM-2000E-HF

- Rated for 750-2000 gpm @ 100 psi (2900-7550 LPM @ 7 BAR)
- Pick up rate: 1%
- Stream pattern remotely controlled via robust electronic motor design
- Clear vinyl 9' (2.7 m) pick up hose included
- 3.5" female swivel inlet

Drum Pick Up Kit #3

- Designed for use with SM-1000-HF / SM-1000E-HF
- Allows foam inlet of the nozzle to be pre-connected to a drum or tote of concentrate
- Includes PVC pick up tube with shut-off valve only. Replaces non-valve pick-up tube that comes with nozzle

**Drum Pick Up Kit #4**

- Designed for use with SM-2000-HF / SM-2000E-HF
- Allows foam inlet of the nozzle to be pre-connected to a drum or tote of concentrate
- Includes PVC pick up tube with shut-off valve only. Replaces non-valve pick-up tube that comes with nozzle

FOAM EXPANSION TUBES

Lightweight composite foam tubes are corrosion-resistant and easy to handle with bases that snap securely onto the nozzle in seconds. The foam tubes are specifically designed to require no alteration of the nozzle itself for use. The base of the tube includes large air intakes – expansion rates are easily varied with nozzle pattern.

Model 251-6

Compatible with the following Master Stream nozzles:

- IMS-350/500
- HF-350/500
- CJ-B series

Length: 14.75", Tube Base: Composite

**Model 252-8**

Compatible with the following Master Stream nozzles:

- SM-1250B Series

Length: 16.69", Tube Base: Metal

**Model 253-9**

Compatible with the following Master Stream Nozzles:

- SM-2000B Series
- SM-1000HF Series
- SM-2000HF Series

Length: 16.14", Tube Base: Metal

**Model 257-6**

Compatible with the following Master Stream Nozzles:

- HF13 Series

Length: 14.9", Tube Base: Metal



SMOOTH BORE TIPS

MASTER STREAM

Designed for maximum reach and penetration when combined with an Elkhart Brass monitor, they are available in a variety of discharge sizes to suit any application.

185-B

- Available discharge sizes:
 - 1/2", 5/8", 3/4", 7/8", 15/16", 1", 1-1/8", 1-3/16", 1-1/4"
- Brass construction with satin brass or chrome-plated finish
- 1.5" female inlet



181 Deluge Tip

- Available discharge sizes:
 - 1", 1-1/8", 1-1/4", 1-3/8", 1-1/2", 1-5/8", 1-3/4", 1-7/8", 2", 2-1/4"
- Brass construction with satin brass or chrome-plated finish
- 2.5" female inlet



181-3 Deluge Tip

- Available discharge sizes:
 - 2", 2-1/4", 2-1/2", 3"
- Brass construction with satin brass or chrome-plated finish
- 3.5" female inlet

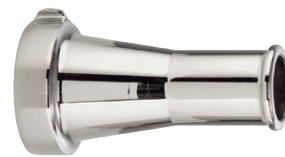

ST-191 Triple Stacked Tip

- Discharges sizes of 1-1/2" / 1-3/4" / 2"
- Brass construction with satin brass or chrome-plated finish
- 2.5" female inlet



ST-191-1 Triple Stacked Tip

- Discharges sizes of 1-3/8" / 1-1/2" / 1-3/4"
- Brass construction with satin brass or chrome-plated finish
- 2.5" female inlet



STREAM SHAPERS

Used to remove turbulence from waterflow and increase stream performance, Elkhart Brass has stream shapers available in a variety of sizes and materials to suit all applications.

282-B Stream Shaper

- Compact design
- Internal vanes help reduce turbulence improving stream reach and quality
- Brass construction with satin brass, chrome-plated, or electroless nickel plated finish
- 2.5" female inlet x 2.5" male outlet



283-B Stream Shaper

- Compact design
- Internal vanes help reduce turbulence improving stream reach and quality
- Brass construction with satin brass or chrome-plated finish
- 3.5" female inlet x 2.5" male outlet



284-B Stream Shaper

- Compact design
- Internal vanes help reduce turbulence improving stream reach and quality
- Brass construction with satin brass or chrome-plated finish
- 3.5" female inlet x 3.5" male outlet





INDUSTRIAL SYSTEMS

Combining modern technology with years of experience, Elkhart Brass industrial firefighting systems are designed for use in many different types of industrial settings, including: refineries, chemical plants, loading docks, tanker berthings, railroad yards and offshore platforms.

A complete Elkhart Brass fire suppression system is composed of hardware, electrical capabilities, programming, and integration of the hardware and software within the facility.

Elkhart Brass customizes all aspects of its approach to deliver an industrial system suited to your needs. Having Elkhart Brass handle your industrial system means your project goes in on schedule, on budget, and performs as expected.

GEN-II ERCM

SECOND GENERATION ELECTRIC REMOTE-CONTROLLED MONITOR

The Elkhart Brass second generation Electric Remote-Controlled Monitor (GEN-II) system design enables the use of a single PLC-based control panel to manage monitor and nozzle motor functions as well as serving as an Operator Control Panel (OCP).



Spit-Fire® Monitor



MCP Main Control Panel



Optional OCP Operator Control Panel



Remote Control Console



Optional MOV Motor Operated Valve



Portable Radio Frequency (RF) Control

RELIABLE FIRE PROTECTION SOLUTIONS FOR INDUSTRIAL LOCATIONS

The GEN-II ERCM system is designed to provide a reliable industrial fire protection solution for Class I or Division 2 classified locations. The electric monitor and nozzle are FM Approved and the control panel is UL Listed.

ERCM KEY FEATURES:

- Up to 2000 gpm (7570 LPM) flow rate
- Up to 300 feet (91 m) stream reach
- 85 brass construction with a lower level of zinc for outstanding resistance to corrosion
- Straight/jet stream to 30° narrow fog and 90° wide fog nozzle flow patterns
- Optional 120° wide fog nozzle for gas mitigation applications
- AC synchronous motors provide continuous oscillation capability without overloading, overheating, or blowing fuses
- Double-race, brass bearings on vertical and horizontal swivels ensures monitor reliability and durability
- Manual override enables manual control at any time even in the event of a power failure
- Communication with facility fire detection and alarm system enables system activation via fire alarm input
- Group response enables grouping and activation of group(s) of monitors
- Input from fire detection system or a panic push button
- Optional touch screen remote control console for operation from control room up to 1.2 miles (2 km) away from hazard
- Optional portable Radio Frequency (RF) control with up to 1000 feet (305 m) range
- Networkable
- Up to 24 monitors per RF transmitter
- Up to 128 monitors per system with HMI via ethernet IP
- Cat 5e copper or fiber (multimode or single mode) networking
- Up to 1.2 miles (2 km) distance between devices with multi-mode or 12.4 miles (20 km) with single mode fiber optic connection. Available with network control panel only
- Complies with NFPA 70

ERCM APPLICATIONS:

- Oil Refineries
- Oil Rigs
- Tank Farms
- Offshore Platforms
- Fueling Areas
- Fuel Docks
- Chemical Processing
- Waste Management
- Helipads
- Airplane Hanger
- Railroad Yards
- Coal Storage
- Lumber Mills
- Paper Mills
- Many More



ERCM GEN-II COMPONENTS

8394-053 Spit-Fire® Monitor

Industrial Electric Remote Controlled Monitor; 120VAC (60 Hz) Synchronous motors; 2,000 gpm (7,570 LPM) max flow rate; 200psi (14 BAR) maximum operating; -45° to +90° (135°) max vertical travel; 347° max horizontal travel; 4.0" 150# ANSI flange inlet; 3.5" NHT male outlet; 85 brass with red urethane enamel; suitable Class I Division 2 classified location application, FM Approved, NFPA 70 (NEC) compliant, NEMA 4X (IP66) junction box.



Main Control Panel (MCP)

Main Monitor Control Panel; Suitable for Class I Division 2 classified location; Factory configured for 3.2A @ 240VAC 60 Hz input power; factory configurable for 50 hz; field configurable for 120VAC or 480VAC; networkable; /Alarm Input / Group Response over ethernet network; 304 Stainless Steel NEMA 4x enclosure; UL Listed, complies with NFPA 70 (NEC).



- Optional 304 and 316 Stainless Steel NEMA 4x Enclosure or painted carbon steel NEMA 4 Enclosure
- Optional gland plate
- Optional multi-mode fiber optic network module
- Optional auxiliary device controls

Networked Operator Control Panel (OCP)

Optional Operator Control Panel (OCP); Suitable for Class I Division II classified location; 6.3A/3.2A @ 120/240VAC 50/60 Hz; networkable; Alarm Input / Group Response over ethernet network; 304 Stainless Steel NEMA 4x enclosure; UL Listed, complies with NFPA 70 (NEC).



- Optional Hazardous Location rated (Class I Division 2)
- Optional 304 and 316 Stainless Steel NEMA 4x Enclosure or painted carbon steel NEMA 4 Enclosure
- Optional gland plate
- Optional multi-mode fiber optic network module
- Optional auxiliary device controls

Hardwired Operator Control Panel

Optional Operator Control Panel (OCP); Power derived from MMCP; 304 Stainless Steel NEMA 4x Enclosure; UL Listed, complies with NFPA 70 (NEC).

- Optional Hazardous Location rated (Class I Division 2)
- Optional 316 Stainless Steel NEMA 4x Enclosure or painted carbon steel NEMA 4 Enclosure
- Optional gland plate
- Optional auxiliary device controls

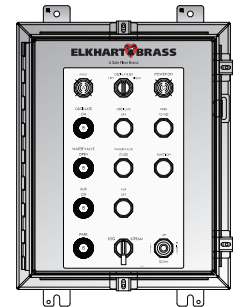

GEN-II XT Extreme Temperature Panels available with higher temperature range

Optional RF Control

Optional RF control enables portable Radio Frequency (RF) control; 1000 feet (305 m) RF control range; networkable with up to 24 monitors per network system.

- Custom control buttons and switches are available



Optional Touch Screen Remote Control Console

Optional remote control console; 100-120VAC @ 2.1A input power; painted carbon steel; touch screen; supports up to 128 monitors.

- 220-240VAC @ 1.0A optional input power
- Optional wall-mount, free-standing console, or desktop
- Consolette enclosures
- Optional fiber communication connections
- Optional EWON device (for remote system access for troubleshooting and support)
- Optional Ergonomic Multi Axis Joystick (on free standing console only)



Optional Motor Operated Valve (MOV)

- 4.0" Electric Butterfly Valve
- Can be used on remote controlled monitor systems
- Temperature range: -40 to 149°F; Stainless Steel valve with EPDM seat; 120-240VAC 50/60 Hz., 1-phase operating power; NEMA 4, 4x and 6, IP66/68; operating pressure - 150 PSI
- FM Approved: Class I Zone 1; AEx/Ex de IIB T5: Acceptable for Class I, Div. 2, Groups C and D, T5 Class II, Div. 2 Groups E, F, and G, Class III: T4



ATEX

CERTIFIED ELECTRIC REMOTE-CONTROL INDUSTRIAL FIRE SUPPRESSION SYSTEM

The Elkhart Brass ATEX and IECEx certified remote-control fire protection system is designed to provide reliable industrial fire protection solution for Zone 1, Zone 2, Zone 21, Zone 22 classified location applications.



Spit-Fire® Monitor



Control Panel



Remote Control Console



Portable Radio Frequency (RF) Control



Optional MOV Motor Operated Valve



ATEX SYSTEM KEY FEATURES:

- 2000 gpm (7570 LPM) maximum flow rate
- Up to 300 feet (91m) stream reach
- 85 Brass monitor construction for corrosive environment and sea water applications
- Ex d flameproof and Ex e increased safety control panel enclosure
- AC synchronous motors operated monitor for heavy-duty cycle and no risk of overheating
- Double-race brass bearings on vertical and horizontal swivels ensure monitor reliability and durability
- Manual override enables manual control at any time as desired
- Automatic horizontal oscillation available with networked control panel only
- Communication with facility fire detection and alarm system enables system activation via fire alarm input. Available with network control panel only
- Group response enables grouping and activation of group(s) of monitors with input from fire detection system or a panic push button. Available with network control panel only
- Optional touch screen HMI control for operation from 1.2 miles (2 km) distance with multi-mode or 62 miles (100 km) distance with single-mode fiber optic connection. Available with network control panel only
- Optional portable Radio Frequency (RF) control with up to 1000 feet (305 m) range. Available with network control panel only
- Networkable (available with network control panel only)
- Up to 24 monitors per RF transmitter
- Up to 24 monitors per system to 128 monitors per system
- Cat 5e copper or fiber (multimode or single mode) networking. Available with network control panel only
- Up to 1.2 mile (2 km) distance between devices with multi-mode or 12.4 miles (20 km) with single mode fiber optic connection. Available with network control panel only
- Integration with field devices such as flame and heat detection systems. Available with network control panel only
- 5-year limited warranty for monitor system and 2-year limited warranty for control panels

CLASSIFIED LOCATIONS:

The Elkhart Brass ATEX certified Electric Remote-Controlled fire suppression system is designed to provide reliable industrial fire protection solution for the following classified locations.

- ATEX Zone 1, Zone 2, Zone 21, Zone 22
- IECEx Zone 1, Zone 2, Zone 21, Zone 22
- Ex db eb h IIC4 Gb
- Ex h tb IIIC T130° C Db

ATEX CERTIFIED ERCM

8394-159 Spit-Fire® Monitor Electric Remote Controlled Monitor

220-240VAC (50/60 Hz) Synchronous motors; 2,000 gpm (7,570 LPM) max flow rate; 200 psi (14 BAR) maximum operating pressure; -45 to +90 (135) max vertical travel; 347 max horizontal travel; 4.0" 150# ANSI flange inlet; 3.5" NHT male outlet; 85 brass with red urethane enamel; suitable for ATEX Zone 1, Zone 2, Zone 21, Zone 22 and IECEx Zone 1, Zone 2, Zone 21, Zone 22; ATEX and IECEx certified, red paint finish.



SM-1250BE-HL ATEX Nozzle

220-240VAC (50/60 Hz) pattern control synchronous motor; 75 psi (5.17 BAR); 3.5" NH female base constant flow; 230 ft (70m) effective reach; straight stream; narrow fog (30) and wide fog (90); 350 to 1250 gpm (1,330 to 4,750 LPM) flow rate; brass; suitable for ATEX Zone 1, Zone 2, Zone 21, Zone 22 and IECEx Zone 1, Zone 2, Zone 21, Zone 22 classified locations; ATEX and IECEx certified, NFPA 70 (NEC) compliant.



SM-2000BE-HL ATEX Nozzle

220-240VAC (50/60Hz) pattern control synchronous motor; 75 psi (5.17 BAR); 3.5" NH female base constant flow; 320 ft (98m) effective reach; straight stream; narrow fog (30) and wide fog (90); 500 to 2000 gpm (1,900 to 7,600 LPM) flow rate; brass; suitable for ATEX Zone 1, Zone 2, Zone 21, Zone 22 and IECEx Zone 1, Zone 2, Zone 21, Zone 22 classified locations; ATEX and IECEx certified, NFPA 70 (NEC) compliant.



Standard Panel Local Control Panel

Monitor motor and operator control panel with controls for basic monitor function and water valve operation; suitable for ATEX Zone 1, Zone 2, Zone 21, Zone 22 and IECEx Zone 1, Zone 2, Zone 21, Zone 22; classified location; 240VAC 50/60 Hz input voltage; Ex d flameproof enclosure joined with Ex e increased safety enclosure; gland plate included.



Network Panel Local Control Panel

Machine motor and operator control panel with a complete panel of function controls; suitable for ATEX Zone 1, Zone 2, Zone 21, Zone 22 and IECEx Zone 1, Zone 2, Zone 21, Zone 22; classified location; 240VAC 50 Hz input voltage; factory configurable to run on 60 Hz; networkable; Alarm Input/Group Response over Ethernet network; Ex d flameproof enclosure joined with Ex e increased safety enclosure; gland plate included.



- Optional multi-mode fiber optic network module
- Optional RF control
- Optional Remote HMI control

RF Control

Provide wireless control of up to 24 monitors per belly pack. Handheld options available. ATEX Zone 1 certified.



Remote HMI Touchscreen Controller

Provides Control for up to 128 Monitors. Intuitive touchscreen controller, providing all Operator Control Panel functions and advanced programming and troubleshooting functions; 120/240VAC (50/60 Hz); UL Listed; painted carbon steel.

- Optional wall-mount, free-standing console, or desktop console enclosure
- Optional fiber communication connections
- Optional EWON device (for Elkhart Brass remote system troubleshooting)
- Optional Ergonomic Multi Axis Joystick (Available on free standing console only) (Not UL Listed)



HRCM

HYDRAULIC REMOTE CONTROL FIRE PROTECTION SYSTEM

The new Elkhart Brass hydraulic remote control system is feature rich and offers the most cost-efficient and reliable industrial fire protection solution of its class.

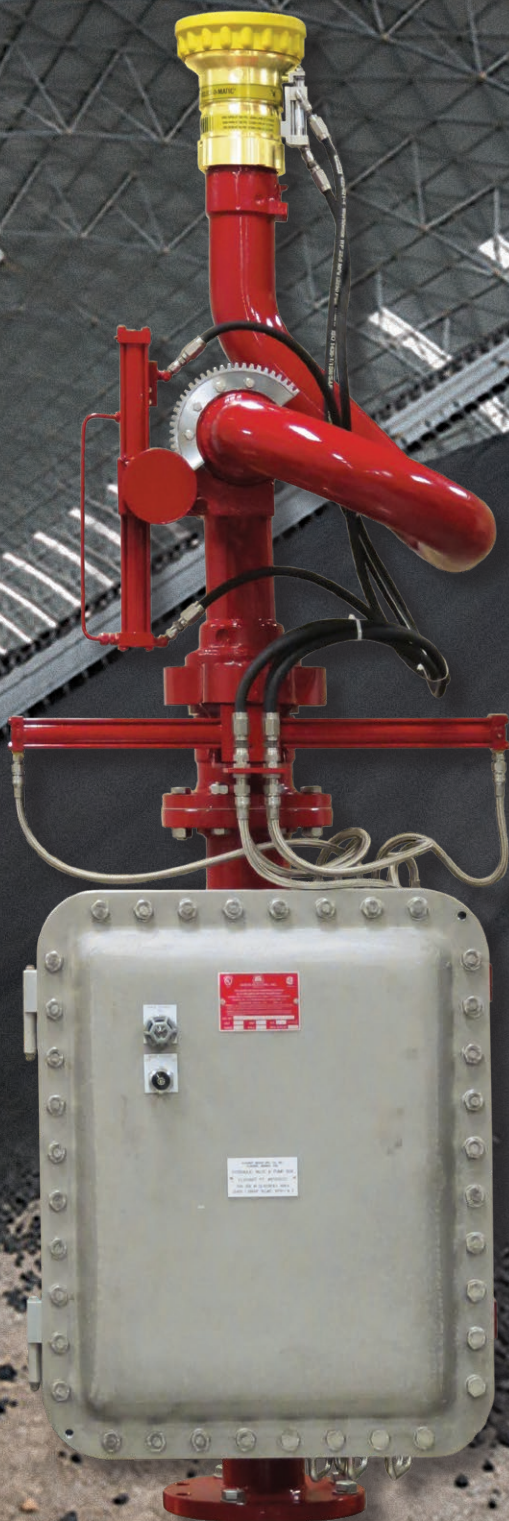

Monitor and Hydraulic Actuation System



Operator Control Panel (OCP)



Remote Control Console



Portable Radio Frequency (RF) Control

The Elkhart Brass hydraulic remote-control fire protection system is designed to provide reliable industrial fire protection solutions for Class I, Class II and Class III classified locations. The fully remote controllable solution design enables ease of install and operation and incorporates high-quality, system reliability and flexibility required for modern industrial fire protection application.

HRCM KEY FEATURES:

- Available with optional absolute position feedback via analog encoders. This enables monitors to maintain pre-programmed coordinates after power loss
- Suitable for following classified areas
 - Class I, Division 1, Groups B, C, D, T6
 - Class II, Division 1, Groups F & G, T6
 - Class III, Division 1
- 85 Brass monitor construction for corrosive environment and sea water applications
- Double-race, brass bearings on vertical and horizontal swivels ensures monitor reliability and durability
- Automatic oscillation available with optional encoders
- Communication with facility fire detection and alarm system enables system activation via fire alarm input
- Group response enables grouping and activation of group(s) of monitors with input from fire detection system
- Networkable
 - Up to 24 monitors per system with RF network
 - Up to 128 monitors per system with Operator Control Panel (OCP) network via ethernet IP
 - Cat 5e copper or fiber (multimode or single mode) networking
 - Up to 1.2 miles (2 km) distance between devices
- Optional portable Radio Frequency (RF) control with up to 1000 feet (305 m) range
- Integration with ancillary devices such as flame and heat detection systems
- NEMA 4x OCP enclosure enables outdoor mount of the OCP
- 5-year limited warranty for monitor system and 2-year limited warranty for control panels/units

HRCM APPLICATIONS:

- Oil Refineries
- Oil Rigs
- Petrochemical Processing Plants
- Tank Farms
- Fueling Areas
- Docks
- Coal Storage
- Sulfur Storage
- Sugar Storage
- Chemical Processing
- Lumber Mills
- Paper Mills

HRCM

HYDRAULIC REMOTE CONTROL FIRE PROTECTION SYSTEM (CONTINUED)



SELECT WITH CONFIGURATION EXAMPLE #1

The select package prevents local operator exposure to the hazard with an Operator Control Panel (OCP) outside of the hazard zone. Capable of system activation via facility fire alarm input.

- Optional RF control for up to 24 monitors per system



PREMIUM WITH CONFIGURATION EXAMPLE #2

The premium package prevents local operator exposure to the hazard with (OCP) outside of the hazard zone and enable control from remote location via HMI console.

- Capable of system activation via facility fire alarm input
- Capable of manual override with either OCP left/right, up/down and straight/fog toggle switches or via remote HMI console
- Networkable with either fiber (multimode/single mode), Cat 5e copper. Up to 128 monitors per network system
- Capable of group activation
- Optional RF control available



OPTIONAL

RF Control Optional RF control enables portable Radio Frequency (RF) control.

- Up to 1000 feet RF control range (305 m)
- Optional RF control for up to 24 monitors per system



CUSTOMIZABLE CONFIGURATIONS

Elkhart Brass has a long history of providing customizable, configurable product solutions to its customers. Fire protection systems throughout the world rely on our experience to not only listen to your needs, but deliver top-quality, manufactured products designed to work better. Visit the Elkhart Brass website today to learn more, or contact a representative for a truly custom, personal experience.

HAVE IT YOUR WAY

HYDROBLAST™

AUTOMATED REMOTE CONTROL MONITOR SYSTEM



The Elkhart Brass fully automated, remote-controllable and configurable HydroBlast™ monitor is designed to provide the flexibility and reliability required for automatic mining vehicles and equipment washdown, aircraft wash and non-classified location fire suppression applications.

Designed for frequent, repeated and multi-spray pattern applications, the HydroBlast™ is equipped with seal and bearing designs that provide ultimate protection against fine mining dust and water ingress to ensure durability. In addition, the HydroBlast system offers programming and configuration flexibility that enables customers to choose from utilizing the HydroBlast remote control system or using customer plant PLC control unit to control the functions of the HydroBlast system. The HydroBlast system is feature rich and offers the industry's most cost-efficient and reliable solutions in its class.



HYDROBLAST KEY FEATURES:

Durability

- Heavy-duty cycle motors
- Thrust bearing design
- Industrial grade bearings
- Industrial grade seals
- IP68 rated monitor

Safety

- Mechanical stop limits
- Programmable stops
- Absolute positioning sensing

Configurable

- Field programmable
- Learn feature via joystick operation
- Customer defined wash sequence

Versatile

- Automatic activation of recipe via asset tag

- Local joystick control for recipe creation
- Modular expandable
- Networkable via Internet IP, Modbus
- TCP, CANbus, Bluetooth and Bluetooth low energy

Built to Last

- Optional SS protective cage to protect against fast moving ore
- Corrosion resistant 85 brass construction
- Industrial grade bearings
- Industrial grade seals
- Protective motor covers
- Protective bumper to protect nozzle against impact

Ease of Install & Service

- Low profile – easy to install
- Event log

- Real time troubleshooting instructions
- Automatic event driven email notification
- Remote diagnostics

Performance

- 50-700 gpm (180 to 2550 LPM) flow rate
- Max operating pressure: 250 psi (17 BAR)
- Vertical Oscillation: -45° to +90°
- Horizontal Oscillation: 350°
- Stream reach: Up to 271 ft (83 m)
- +/-0.5° positioning accuracy
- Absolute positioning feedback
- Ambient temp rating: -13° F to 149° F (-25° C to 65° C)

HYDROBLAST APPLICATIONS:

- Dust mitigation applications
- Mining and construction equipment cleaning
- Mining fire protection applications
- Chute cleaning
- Damper bin cleaning
- Reclaimer cleaning
- Conveyor belt cleaning
- Mining vehicle washdown
- Rail cars washdown
- Lumber mills
- Construction equipment washdown
- Dust mitigation
- Arena fire protection
- Stadium fire protection
- Convention center fire protection
- Waste recycling plant fire protection
- Waste treatment overflow tank cleaning



HYDROBLAST™

AUTOMATED REMOTE CONTROL MONITOR SYSTEM (CONTINUED)

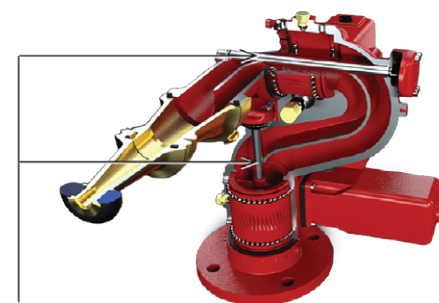
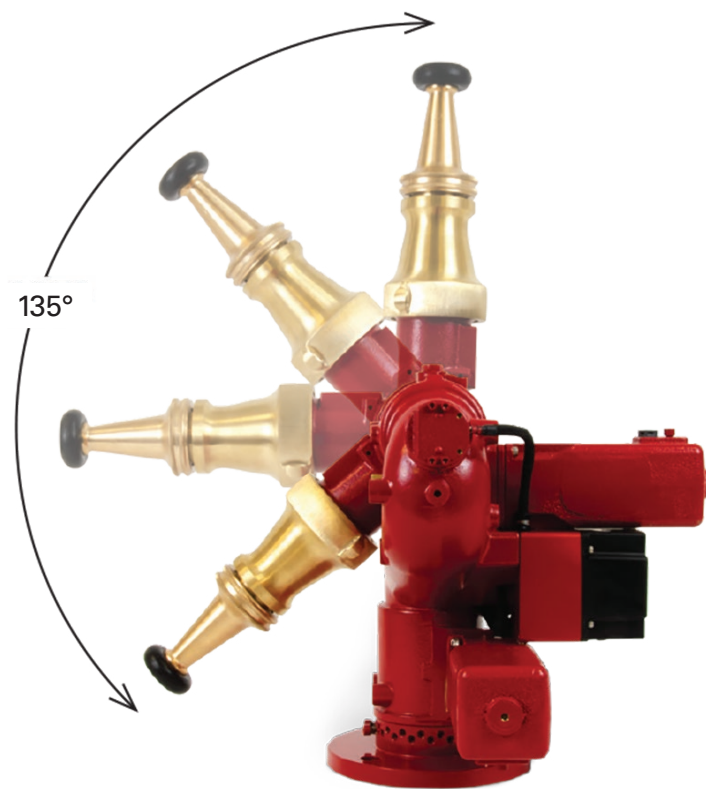

Thrust rods and bearings reduce wear on joints to improve life cycle and durability.

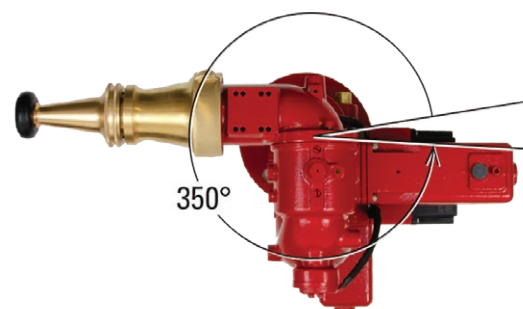

SYSTEM MONITOR OPTIONS



HydroBlast™

- Rated up to 750 gpm (2900 LPM)
- Rugged 85 brass construction
- Heavy-duty use



Cobra™ EXM2

- Rated up to 1250 gpm (4750 LPM)
- Teflon-impregnated hard-coated finish
- Lightweight aluminum construction



Sidewinder® EXM2

- Rated up to 750 gpm (2900 LPM)
- Teflon-impregnated hard-coated finish
- Lightweight aluminum construction



Scorpion® EXM2

- Rated up to 2500 gpm (9500 LPM)
- Teflon-impregnated hard-coated finish
- Lightweight aluminum construction

HYDROBLAST MONITOR SYSTEM

Designed for frequent, repeated and multi-spray pattern applications, the HydroBlast is equipped with seal and bearing designs that provide ultimate protection against fine mining dust and water ingress to ensure durability.

- Field programmable HMI touch screen for managing the functions of up to 16 independent monitors
- Learn feature via joystick operation enables field configuration of spray patterns for fire suppression and wash down applications
- Real time troubleshooting via HMI control unit enables system diagnostics from remote location
- Heavy-duty 85 brass monitor for corrosive and non-corrosive environment applications
- Lightweight Teflon impregnated hard anodized aluminum monitors for non-corrosive environment applications

INDUSTRIAL AND ELECTRIC FOG

HANDLINE NOZZLES

205-B Industrial Nozzle

Constructed out of brass materials, 205-B nozzles are built to last and are maintenance free. They are easy to operate and provide straight/jet stream, narrow fog and wide fog stream patterns.

- 170 gpm @ 100 psi (650 LPM @ 7 BAR)
- 250 gpm @ 100 psi (950 LPM @ 7 BAR)
- 1.5" inlet

205-EB Electrical Fog Nozzle

205-EB electrical fog nozzles are designed to be used in class 'C' hazard applications and utilize only fog capabilities in combating blazes at 10-feet or more from electrical equipment with up to 250,000 voltage.

- 170 gpm @ 100 psi (650 LPM @ 7 BAR)
- 250 gpm @ 100 psi (950 LPM @ 7 BAR)
- 1.5" inlet
- Consistent fog pattern to prevent electrocution from fighting fires of energized electrical equipment

L-205-B Industrial Nozzle

Constructed out of brass materials, L-205-B nozzles are built to last and are maintenance free. They are easy to operate and provide straight/jet stream, narrow fog and wide fog stream patterns.

- 60 gpm @ 100 psi (230 LPM @ 7 BAR)
- 95 gpm @ 100 psi (360 LPM @ 7 BAR) UL Listed
- 125 gpm @ 100 psi (475 LPM @ 7 BAR) UL Listed
- 1.5" inlet



Elkhart Brass industrial handline and electrical fog nozzles are designed for deployments by industrial fire brigades in refineries, chemical plants, office complexes and other on-site emergency situations. These nozzles are designed for aggressive industrial environment, and most comply with the current edition of the UL 401 standard.

KEY FEATURES:

- Most models are UL Listed to current edition of the UL401 standard for combating class A & B fire
- Flush feature enables debris passage through the nozzle with no adverse effect on the functionality of the nozzle
- Knurled grip ensures fast deployment and shutoff of the nozzle

L-205-EB Electrical Fog Nozzle

The L-205-EB electrical fog nozzles are designed to be used in class 'C' hazard applications and utilize only fog capabilities in combating blazes at 10-feet or more from electrical equipment with up to 250,000 voltage.

Constructed out of brass materials, L-205-EB nozzles are built to last and are maintenance free. They are easy to operate and provide straight/jet stream, narrow fog and wide fog stream patterns.

- 60 gpm @ 100 psi (230 LPM @ 7 BAR)
- 95 gpm @ 100 psi (360 LPM @ 7 BAR) UL Listed
- 125 gpm @ 100 psi (475 LPM @ 7 BAR) UL Listed
- 1.5" inlet
- Consistent fog pattern to prevent electrocution from fighting fires of energized electrical equipment



D-205-B Industrial Nozzles

Constructed out of brass materials, D-205-B nozzles are built to last and are maintenance free. They are easy to operate and provide straight/jet stream, narrow fog and wide fog stream patterns.

- 170 gpm @ 100 psi (650 LPM @ 7 BAR)
- 250 gpm @ 100 psi (950 LPM @ 7 BAR)
- 1.5" inlet
- UL Listed



D-205-EB Electrical Fog Nozzle

The D-205-EB electrical fog nozzles are designed to be used in class 'C' hazard applications and utilize only fog capabilities in combating blazes at 10-feet or more from electrical equipment with up to 250,000 voltage.

- 170 gpm @ 100 psi (650 LPM @ 7 BAR)
- 250 gpm @ 100 psi (950 LPM @ 7 BAR)
- 2.5" inlet
- Consistent fog pattern to prevent electrocution from fighting fires of energized electrical equipment



MARINE HANDLINE NOZZLES

Elkhart Brass marine handline nozzles are designed for use in marine firefighting applications. These nozzles can stand up to aggressive marine environments, utilize military grade components, and are constructed of marine grade brass. They are suitable for use with AFFF foam for the shipping industry, refineries, offshore rigs, and military applications. Many of them meet the stringent performance requirements of the U. S. Navy and/or U. S. Coast Guard, and are FM Approved.

KEY FEATURES:

- 85 brass construction with a lower level of zinc for outstanding resistance to corrosion
- Heavy-duty manganese/bronze horseshoe shutoff handle
- Constant flow rate from straight steam to wide fog
- Acetal ball with self-adjusting UHMWPE seat
- Flush without shutting down

SELECTABLE FLOW MARINE NOZZLES

SFL-B

- Flow Rates: 40, 60, 95, and 125 gpm @ 100 psi (150, 230, 360 and 475 LPM @ 7 BAR)
- 1.5" inlet

SFL-BG

- Pistol Grip



FIXED FLOW MARINE NOZZLES

SFL-GN-SPL

The Elkhart Brass SFL-GN-SPL handline nozzle is a constant flow, rugged brass handline nozzle designed for use in the harshest environments with an electroless nickel plated coating. It is easy to operate and provides straight/jet stream, narrow fog and wide fog stream patterns.

- 95 gpm @ 100 psi (360 LPM @ 7 BAR)
- 1.5" inlet
- Pistol Grip
- Electroless Nickel Plated
- FM Approved



SFL-N Marine Handline Nozzle

The Elkhart Brass SFL-N marine handline nozzle is a constant flow light weight, rugged brass handline nozzle designed for quick deployment. The SFL-N is easy to operate and provides straight/jet stream, narrow fog and wide fog stream patterns.

- 95 gpm @ 100 psi (360 LPM @ 7 BAR)
- 125 gpm @ 100 psi (475 LPM @ 7 BAR)
- 1.5" inlet



SFL-GN Marine Handline Nozzle

- Pistol Grip
- Complies with Mil-N-24408E Standard

SFL-CG-95 Marine Handline Nozzle

The US Coast Guard approved Elkhart Brass SFL-CG-95 marine handline nozzle is a constant flow rugged brass handline nozzle designed for quick deployment. The SFL-CG-95 is easy to operate and provides straight/jet stream, narrow fog and wide fog stream patterns.

- 95 gpm @ 100 psi (360 LPM @ 7 BAR)
- 1.5" inlet
- FM Approved
- U. S. Coast Guard Approved



SFL-GCG-95 Marine Handline Nozzle

- Pistol Grip
- FM Approved
- U. S. Coast Guard Approved

DSF-N Marine Handline Nozzle

The Elkhart Brass DSF-N marine handline nozzle is a constant flow, rugged brass handline nozzle designed for quick deployment. The DSF-N is easy to operate and provides straight/jet stream, narrow fog and wide fog stream patterns.

- 250 gpm @ 100 psi (950 LPM @ 7 BAR)
- 2.5" inlet
- Complies with Mil-N-24408E Standard



MORE INFORMATION



FIELD KITS

Elkhart Brass offers field service kits for nozzles, valves and appliances. These kits include information on repairs, parts and service. Learn more at elkhartbrass.com or contact a representative today.

TECHNICAL DATA

Available on our website in Technical Data section or by contacting Elkhart Brass direct, find multimedia and other valuable resources for reach, friction loss, flow and performance data, and much more.

MANUALS

Elkhart Brass and its products are supported through comprehensive manuals for most categories. Find downloads at elkhartbrass.com with all of the product information you should need.

SPECIFICATIONS

Downloadable, printable specifications sheets are available for most products at the Elkhart Brass website. You will find tips, sizes, materials used, certain operational instructions, and more.

CUSTOM SOLUTIONS

Elkhart Brass has a long history of providing customizable, configurable product solutions to its customers. Fire protection systems throughout the world rely on our experience to not only listen to your needs, but deliver top-quality, manufactured products designed to work better.

HOW TO ORDER

Sales Managers are listed by your location on our website. This includes The United States, Canada, Mexico, Europe, Africa, Asia, and more. They will assist with information or ordering and will also provide demos of products by request and availability.

OTHER MARKETS WE SERVE

Elkhart Brass has for decades, even over a century with some, served the firefighting equipment and fire protection markets. These include OEM vehicle builders, municipalities throughout the world, industrial customers like mining and construction segments, and building interior safety systems.



FIRE APPARATUS EQUIPMENT



BUILDING SYSTEMS



MUNICIPAL



MINING & CONSTRUCTION

ABOUT SAFE FLEET

In 2015, Elkhart Brass was acquired by Safe Fleet. The corporation's portfolio of brands serves major markets including Emergency, Military, Industrial, Work Truck, Waste, Truck/Trailer, and Bus/Rail/RV. The combination of Elkhart Brass with FRC, FoamPro and ROM enables the company to develop integrated systems of monitors, valves, foam proportioning and electronic controls for the global emergency market. Headquartered in Belton, MO, Safe Fleet employs over 1000 employees. The Safe Fleet family of brands operates over 500,000 square feet of manufacturing space and targets markets with increasing demand for operator, passenger and pedestrian safety. For more information about Safe Fleet you can visit www.safefleet.net.



Driving Safety Forward™



SCHOOL BUS



TRANSIT



LAW ENFORCEMENT & MILITARY



FIRE & EMS



WORK TRUCKS



TRUCK & TRAILER



WASTE & RECYCLING



CONSTRUCTION



TAKE ACTION

elkhartbrass.com

Since 1902 Elkhart Brass has been an innovator in the fire protection and firefighting equipment industries. Today, with well over 2,000 products, the company has become a leader in the various markets served. Find out more by visiting the elkhartbrass.com website, social media channels, Knowledge Drop and other training, educational and product videos; and see more details. There are many resources available to help you find and enjoy the right product solution at Elkhart Brass.

ELKHART BRASS
A Safe Fleet Brand

1302 W Beardsley Ave
Elkhart, IN 46514
+1 (574) 295-8330

Follow us on all of these social media channels for the latest information about Elkhart Brass products.



For official Elkhart Brass merchandise visit our store at www.elkhartbrass.shop





ELKHART BRASS

11-2023

Copyright ©2023 Safe Fleet and its subsidiaries. All rights reserved. No part of this publication may be reproduced by any means without written permission from Safe Fleet. The information in this publication is believed to be accurate. However, Safe Fleet does not make any representation or warranty to that effect and does not assume responsibility for any consequences resulting from use of such information. Revisions or new editions of the publication may be issued (or not issued) in our discretion to incorporate such changes.

+1 574-295-8330
elkhartbrass.com



SAFE  FLEET
Driving Safety Forward™